

Gearbox Actuator With Integrated Valves



Features

- Two way actuator (max +25mm / -25mm) with integrated valves
- No need for extra valve block
- Fully adjustable (washers included in the kit). Stroke adjustable from 12 to 50 mm
- Very compact (measures only 145mm + stroke)
- Very light (only weights 700 g)
- 650 N push and 560 pull force @ 8 bars

Technical specifications

Dimensions L x W x H	172 x 50 x 55 mm	
Weight	700 g	
Operating temperature	-20 ... 80°C	
Operating pressure	6 ... 9 Bar	
Voltage	12 V	
Stroke	50 mm	
	adjustable from 12 to 50 mm	
Operating force [6 Bar]	Push	650 N
	Pull	560 N
Pneumatic fitting	Pneumatic tube 8/6 mm	

Included in the kit

- ① Gearbox actuator with integrated valves
- ② Washers for stroke adjustment
Connector with pins

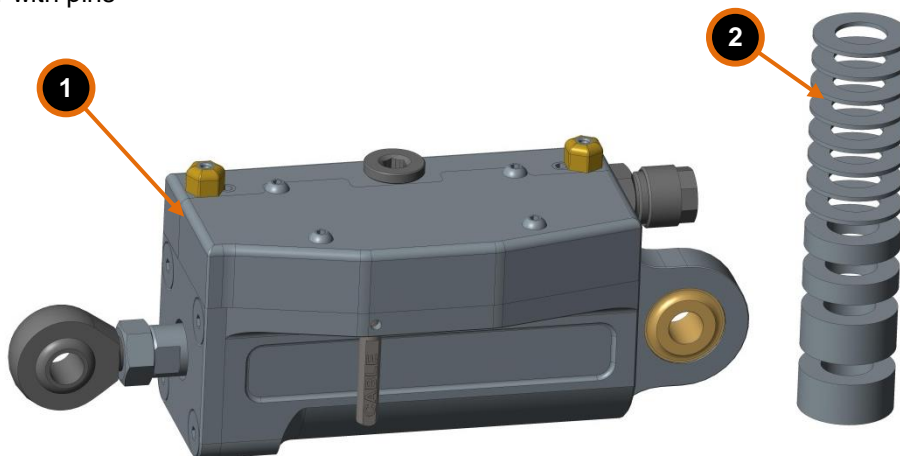

Connection Diagram

- ③ Air supply (Ø 8 mm pneumatic pipe). Swap fitting and plug if needed
- ④ Electrical cable with connector

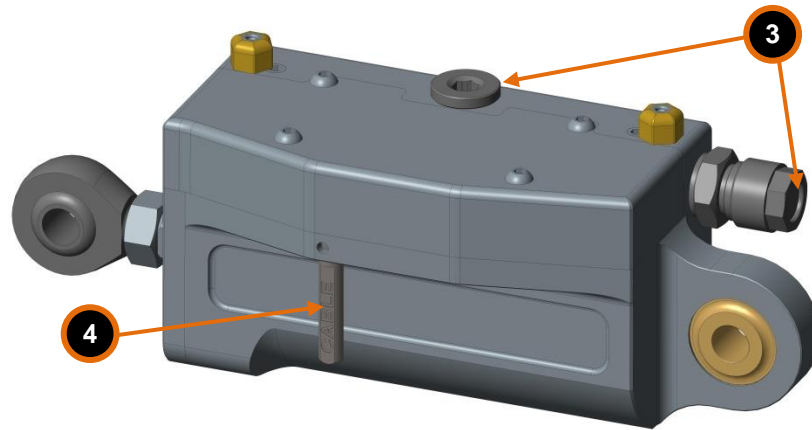

Adjusting the travel

Travel is adjusted by adding or removing washers inside the cylinder. Cylinder has 50 mm stroke without washers (+25mm / - 25mm), by adding 10mm washer you reduce stroke to 40 mm.

1. Measure the stroke of the actuator and the stroke you need.
2. Unscrew the bolts ⑤ and pull out the with the actuator piston.

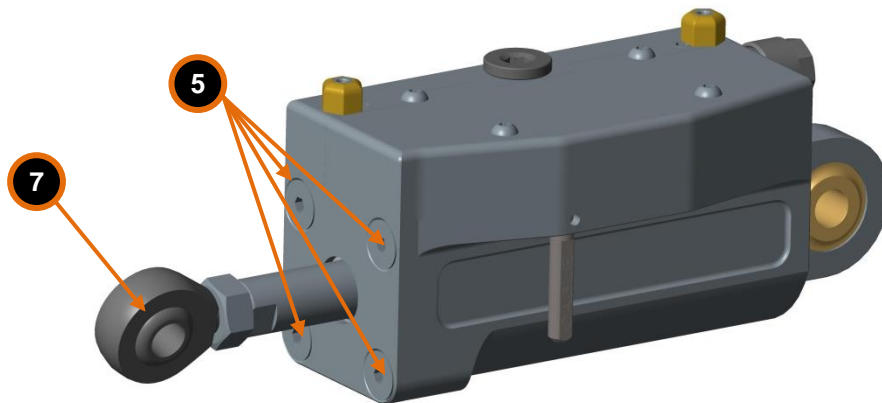

- Remove the rod end ⑦ from the piston rod and pull out the piston rod from the cover. Insert the washer set on the piston rod ⑥ and insert cover back to the piston.

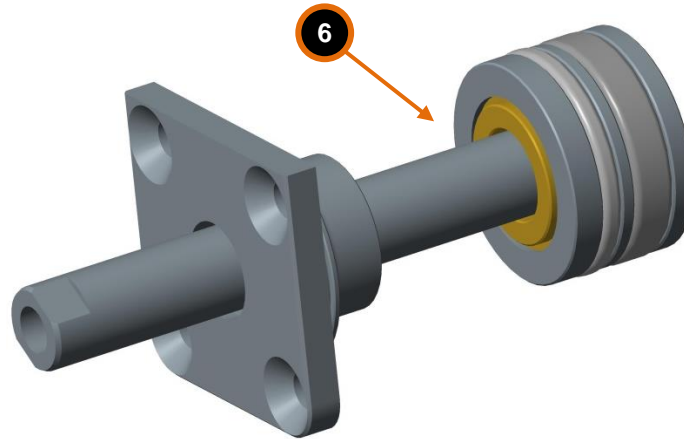

- Insert the piston with the cover back to the actuator and screw bolt back in place. Watch the seals and take care of lubrication when assembling the actuator back (see servicing below)

Electrical diagram

Connector pinout

1	12V
2	OUT
3	IN
4	Not used

Technical drawing

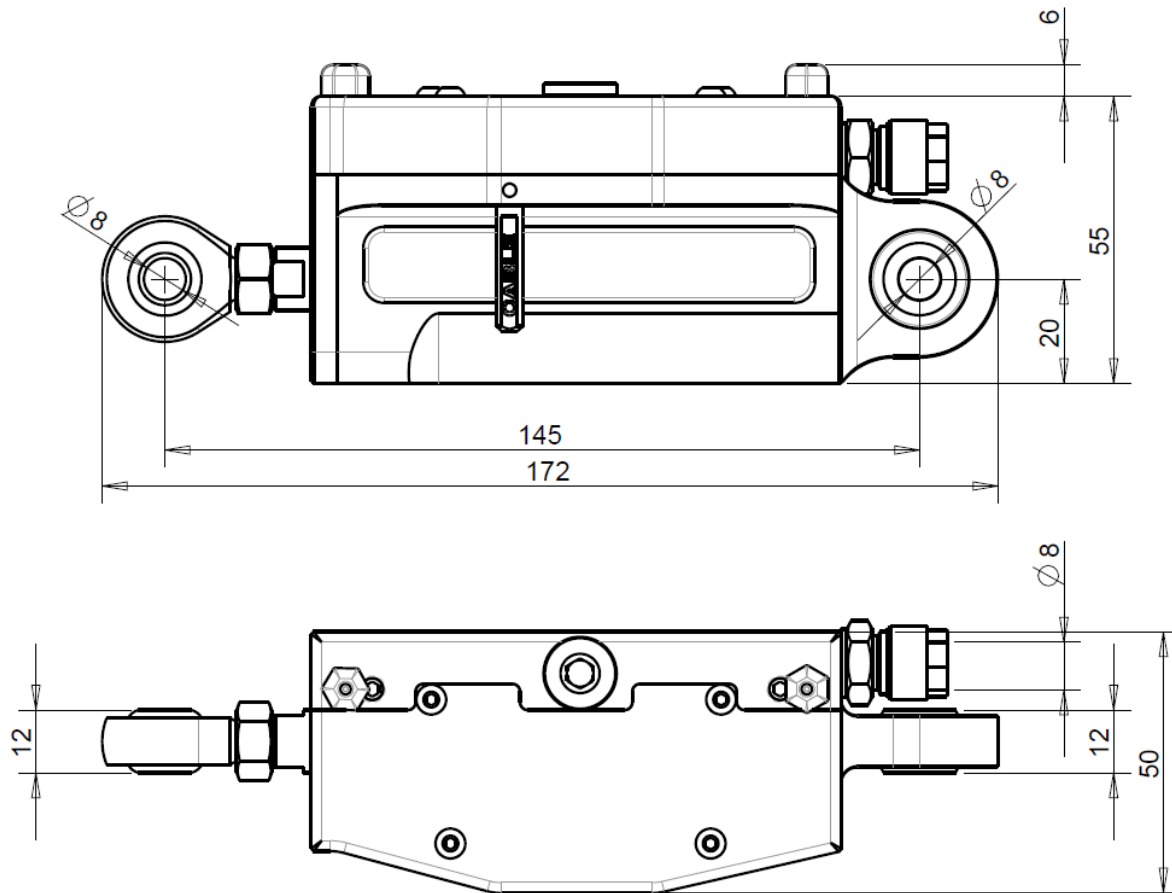

Servicing

If there's any damage to the rod at any time, we recommend replacing the actuator.

Yearly inspection:

- Disassemble the actuator
- Check for any damage to the inside or outside of the actuator
- With piston rod removed, clean the inside and outside of the actuator with gasoline (Do not use Nitroglycerin).
- Seals, bushing and internal cylinder bore should be lubricated with FESTO grease LUB-KB1-SILIKONFREI.